

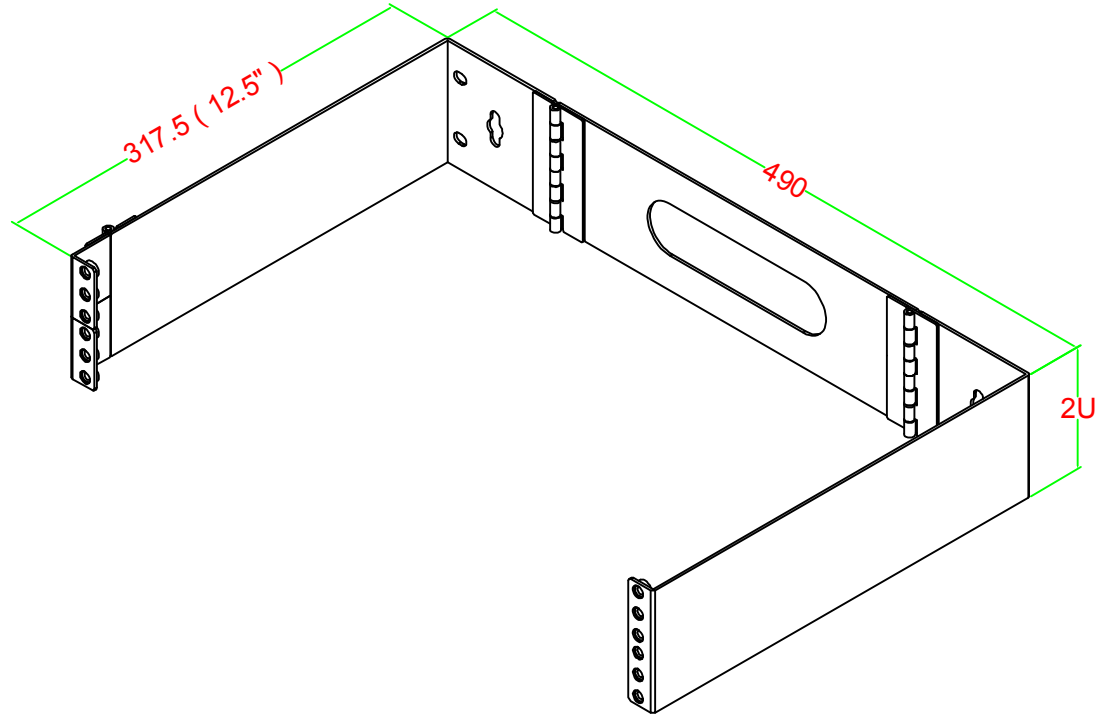

# RACK (19"-2U) / DEPTH=12.5"

Package

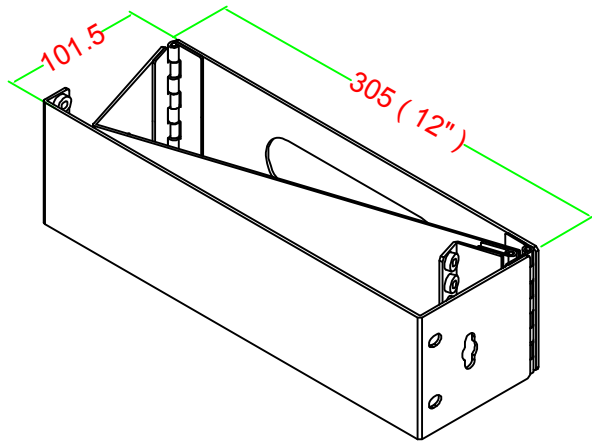

Materials :  
Rack : Metal (SPCC)

 Rack Screw Attached

DRAW NO:		ITEM NO:	WB-19-110-2SH-2U
 APPR		CUSTOMER:	
UNIT: m/m	DESIGN	DATE:	
SCALE:	Ref. NO:	TOLERANCE:	· ± 1 · X ± 0.2 · XX ± 0.15

**Hyperline**  
cabling systems

Hyperline Systems Canada Ltd.