

# RACK (19"-1U) / DEPTH=12.5"

Package

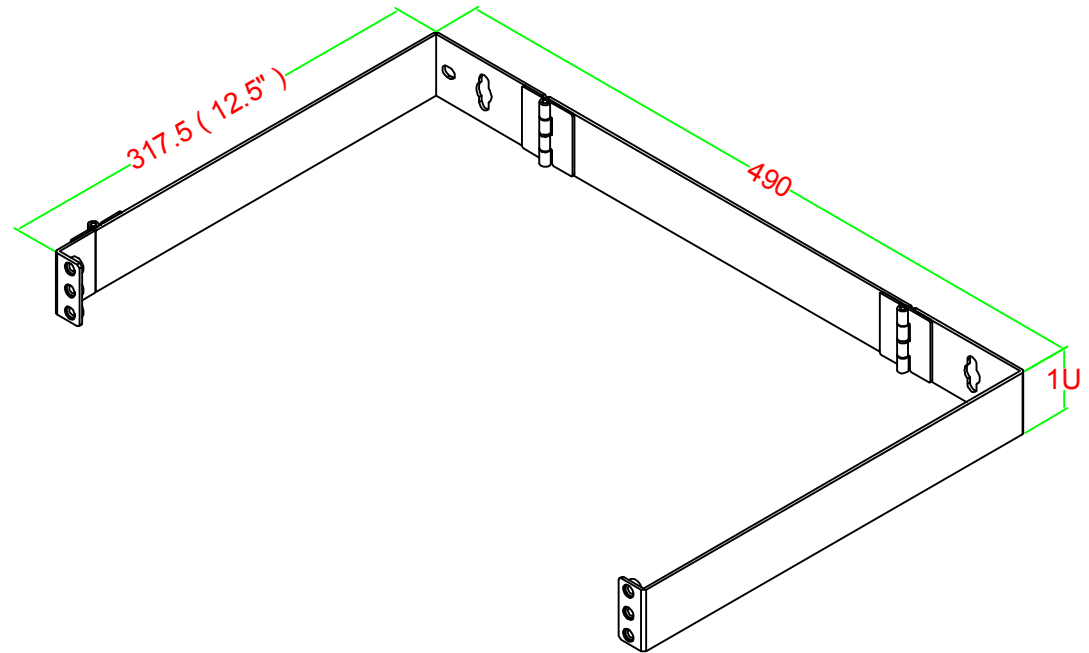

Materials :  
Rack : Metal (SPCC)

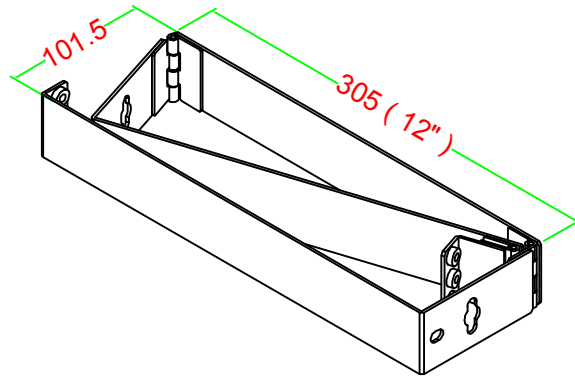

Rack Screw Attached

DRAW NO:		ITEM NO: WB-19-110-2SH-1U	
	APPR	CUSTOMER:	
UNIT: m/m	DESIGN	DATE:	
SCALE:	Ref. NO:	TOLERANCE: · ± 1 · X ± 0.2 · XX ± 0.15	

**Hyperline**  
cabling systems

Hyperline Systems Canada Ltd.