

REVISIONS				
RevNo	Description	Date	Revision	Mender
1				
2				

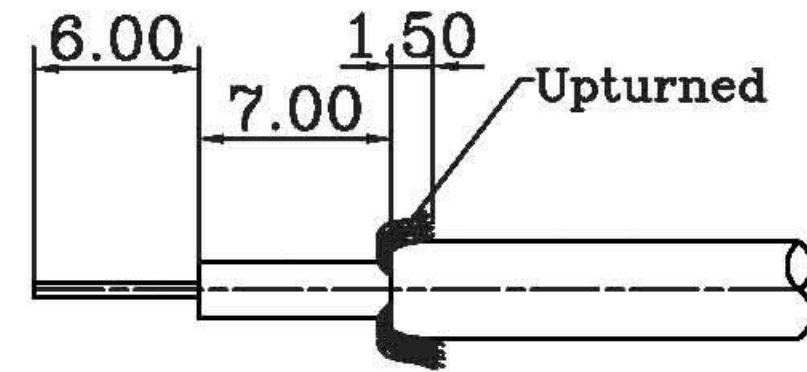

RECOMMENDED
CABLE STRIPPING DIM'S

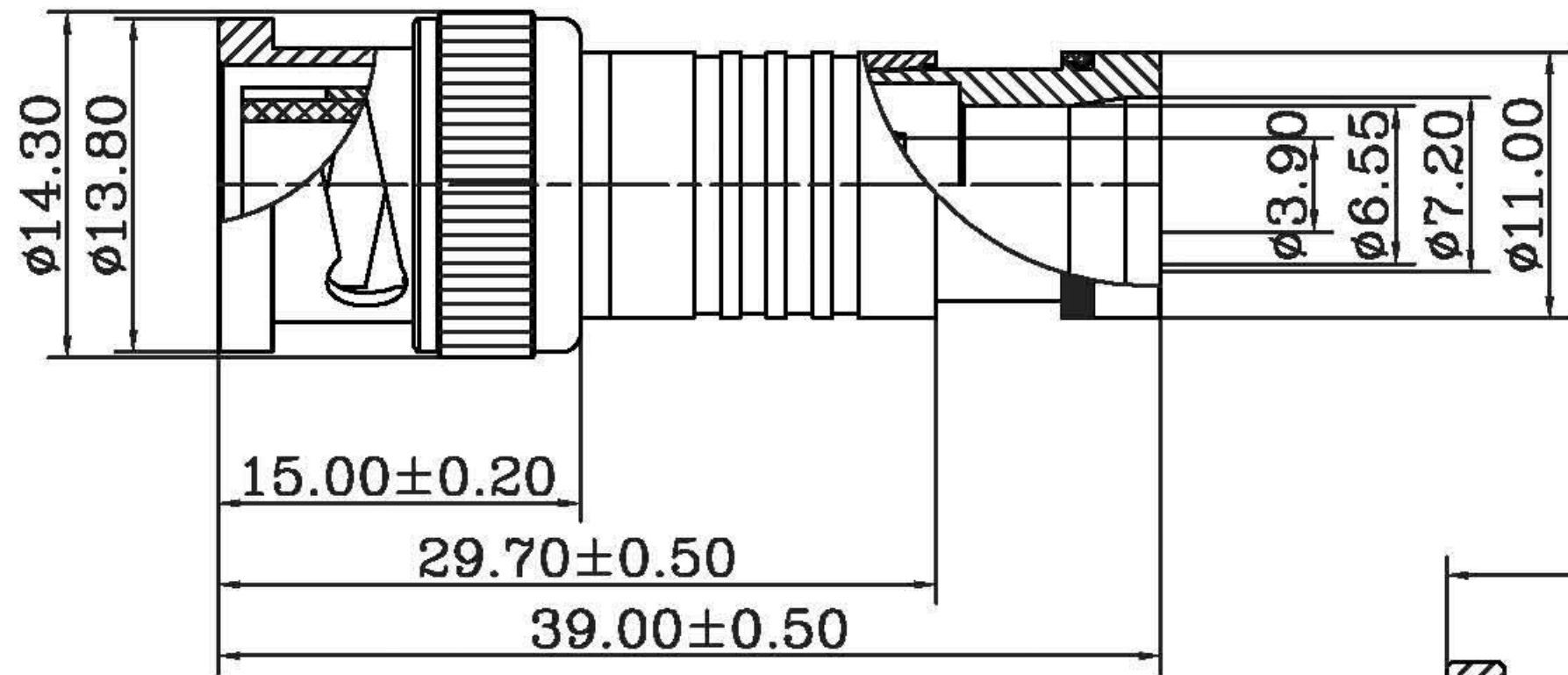
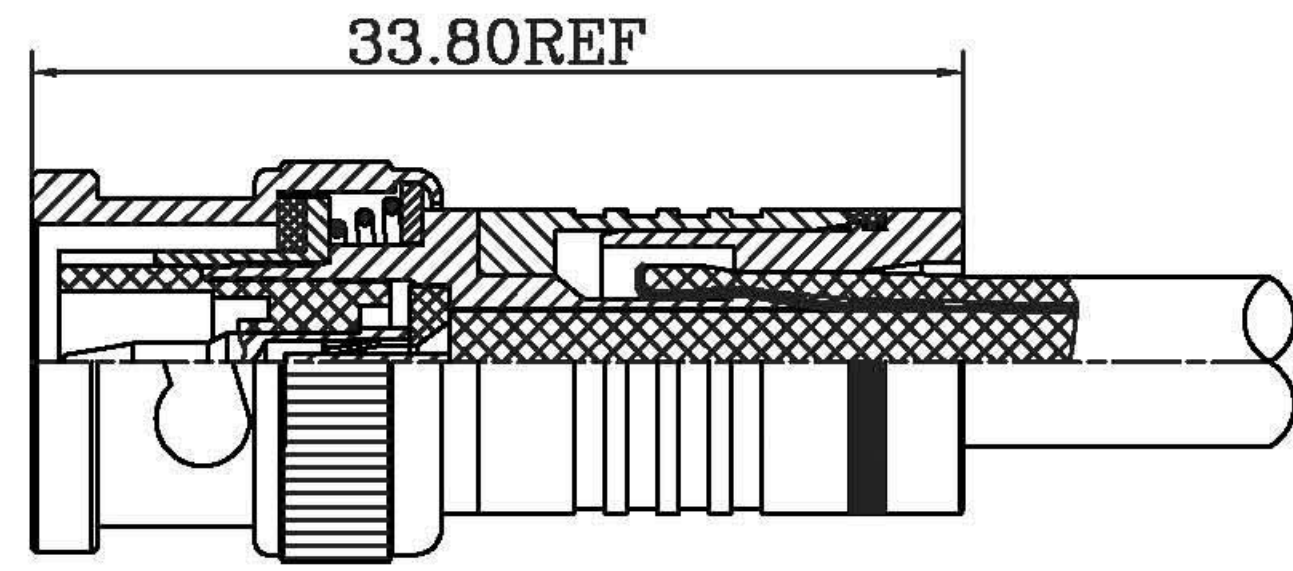

Assemblage

13	INSULATOR	POM	1	NONE
12	CENTER CONTACT	Be,Cu	1	TIN PLATED
11	GASKET	PVC	1	NONE
10	CONTACT PIN	BRASS	1	GOLD PLATED
9	BODY	ZINC	1	NICKEL PLATED
8	BODY	ZINC	1	NICKEL PLATED
7	WASHER	ZINC	1	NICKEL PLATED
6	SPRING	65Mn	1	NONE
5	OUT CONTACT	ZINC	1	NICKEL PLATED
4	GASKET	PVC	1	NONE
3	INSULATOR	POM	1	NONE
2	BODY	BRASS	1	NICKEL PLATED
1	SHELL	ZINC	1	NICKEL PLATED
ITEM	DESCRIPTION	MATERIAL	Q'TY	FINISHED

				TITLE				
				BNC MALE COMPRESSION TYPE FOR RG59U				
PART NAME		△		SCALE	FIT	DESIGNED	<i>Xwj</i>	
MODEL NO.		△		FRACTIONS	±	DRAWING	<i>Xwj</i>	
DRAWING NO.		△		DECIMALS	±0.15	CHECKED		
FINISHNG		△	2004/03/03	A1	ANGLES	±	APPROVED	
MATERIAL		SYM	DATE	REVISION	UNITS	MM	☐ ⊕ 1RD ANGLE	